

The Third Place

Assignment 8A – Final Furniture Plan



Laura Adams IDSN 2102 F20

Assignment 8B – Final Furniture Plan



Laura Adams IDS N 2102 F20

Assignment 9A – Concept

Concept:

- The primary inspiration is the early industrial era and early cigarette/cigar factories
- The design emulates the original look of the Flue Cured Tobacco Barn while taking on the function of a modern coffee house



Barn for Flue Curing

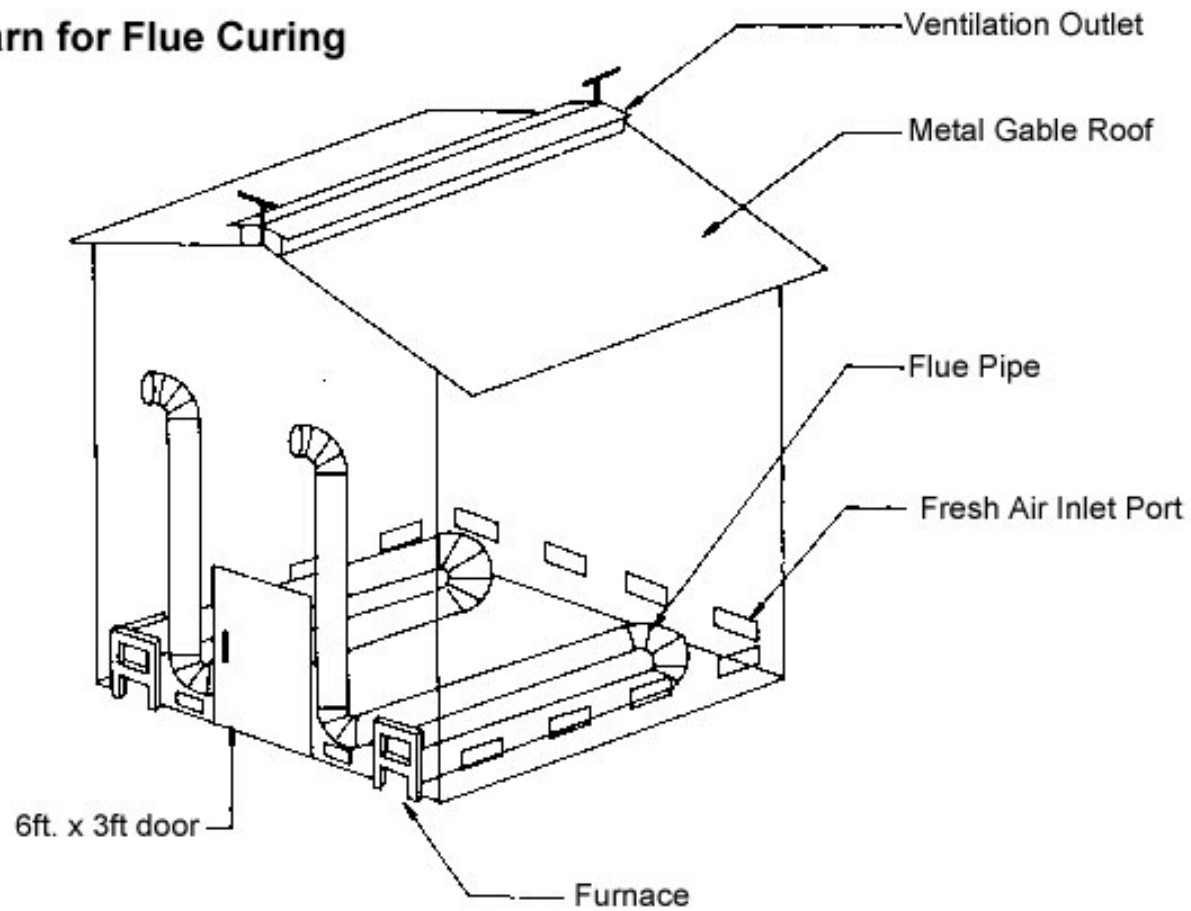

Assignment 9B – Color Rationale

Color Rationale:

- The proposed color palette is inspired by the fields in which tobacco is grown
- The palette pulls on the physical beauty and cultural significance of the surrounding area
- The palette will aide in the development of a relaxing yet productive environment by maintaining a degree of visual softness

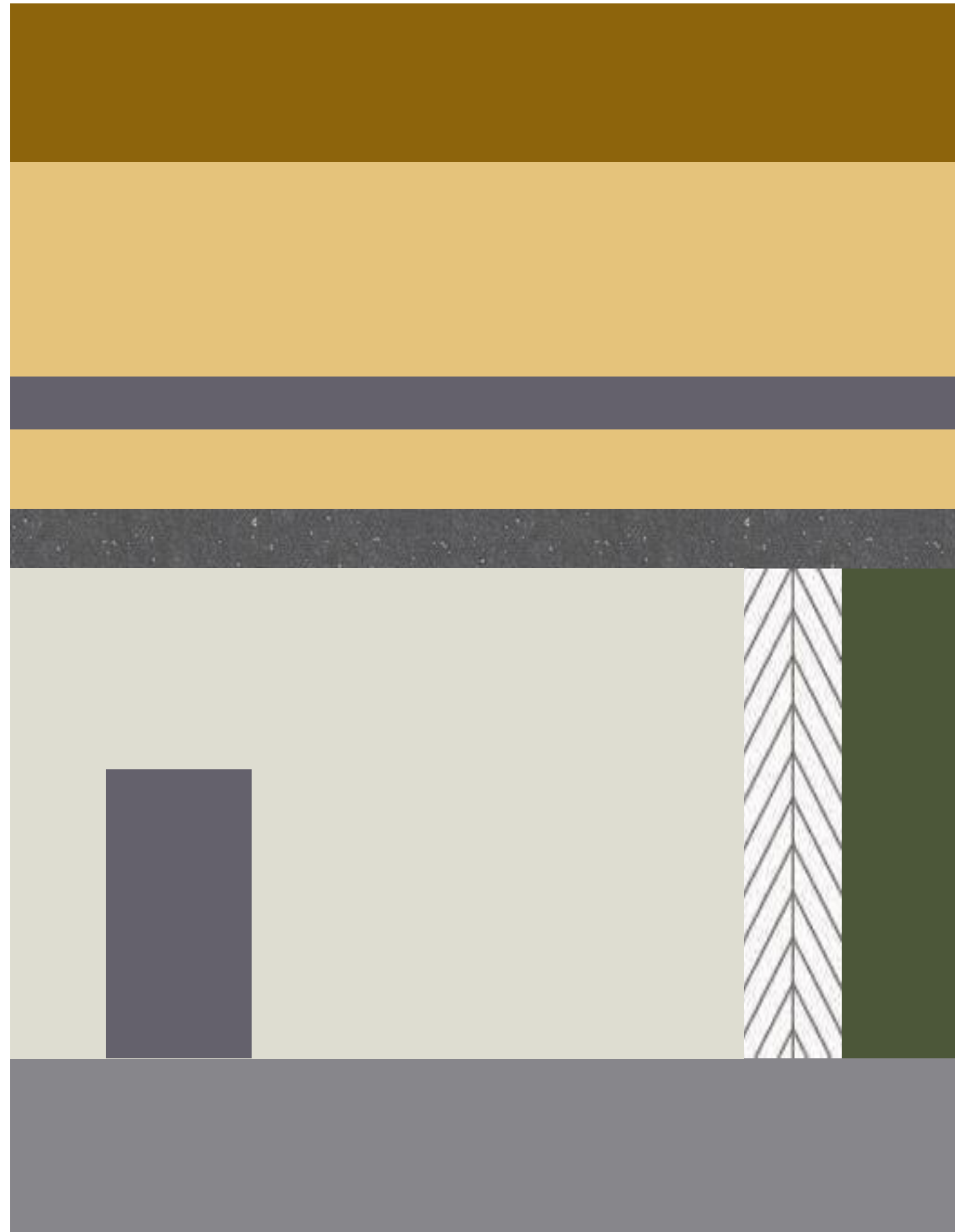

Laura Adams IDS N 2102 F20

Assignment 10 – Stair Model

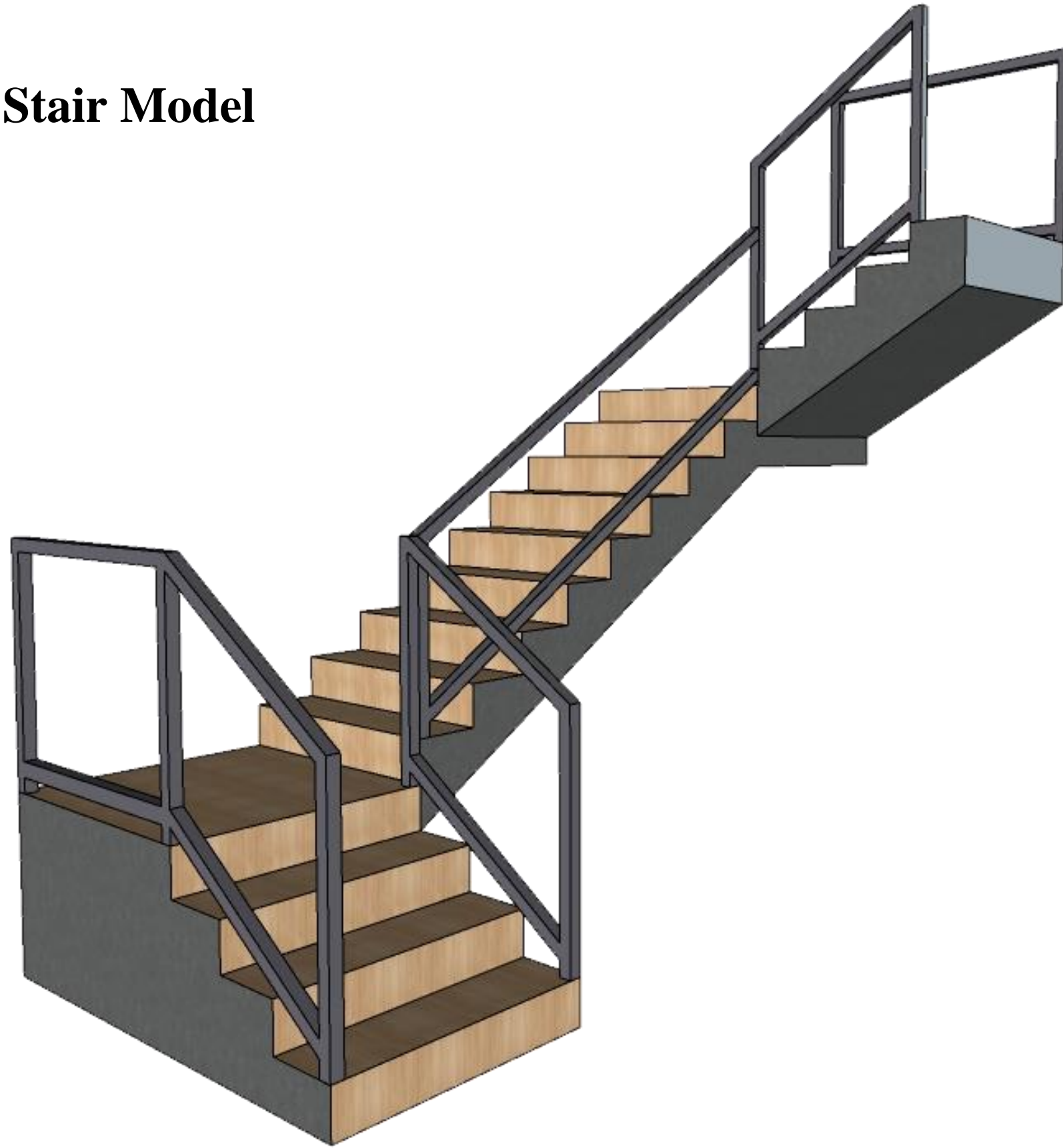

Assignment 11 – Furniture Scene 1



Laura Adams IDSN 2102 F20

Assignment 11 – Furniture Scene 2



Laura Adams IDSN 2102 F20

Assignment 11 – Furniture Scene 3



Laura Adams IDSN 2102 F20

Assignment 11 – Furniture Scene 4



Laura Adams IDSN 2102 F20

Assignment 11 – Furniture Scene 5



Laura Adams IDSN 2102 F20

Assignment 12 – Finishes Scene 1



Laura Adams IDSN 2102 F20

Assignment 12 – Finishes Scene 2



Laura Adams IDSN 2102 F20

Assignment 12 – Finishes Scene 3



Laura Adams IDSN 2102 F20

Assignment 12 – Finishes Scene 4



Laura Adams IDS N 2102 F20

Assignment 12 – Finishes Scene 5



Laura Adams IDSN 2102 F20