

PORTFOLIO 1

Rebecca Joyner

IDSN 3202

FALL 2020

Stakeholder Profile:

The Edgeworth Tobacco Building Richmond, VA

- **Owner/ Client:** Forest City Commercial Group
- **Users:** Businesses renting out co-working office spaces
- Renovated Interior
- New and functional office space while keeping the history of the building



Site Profile:

The Edgeworth Tobacco Building Richmond, VA

- 2100 E. Cary Street
Richmond, VA, United States
- 1920s Tobacco Factory and Warehouse on
Richmond's Historic Tobacco Row
- 166,000 square footage
- Tenant square footage: 10,087 square feet

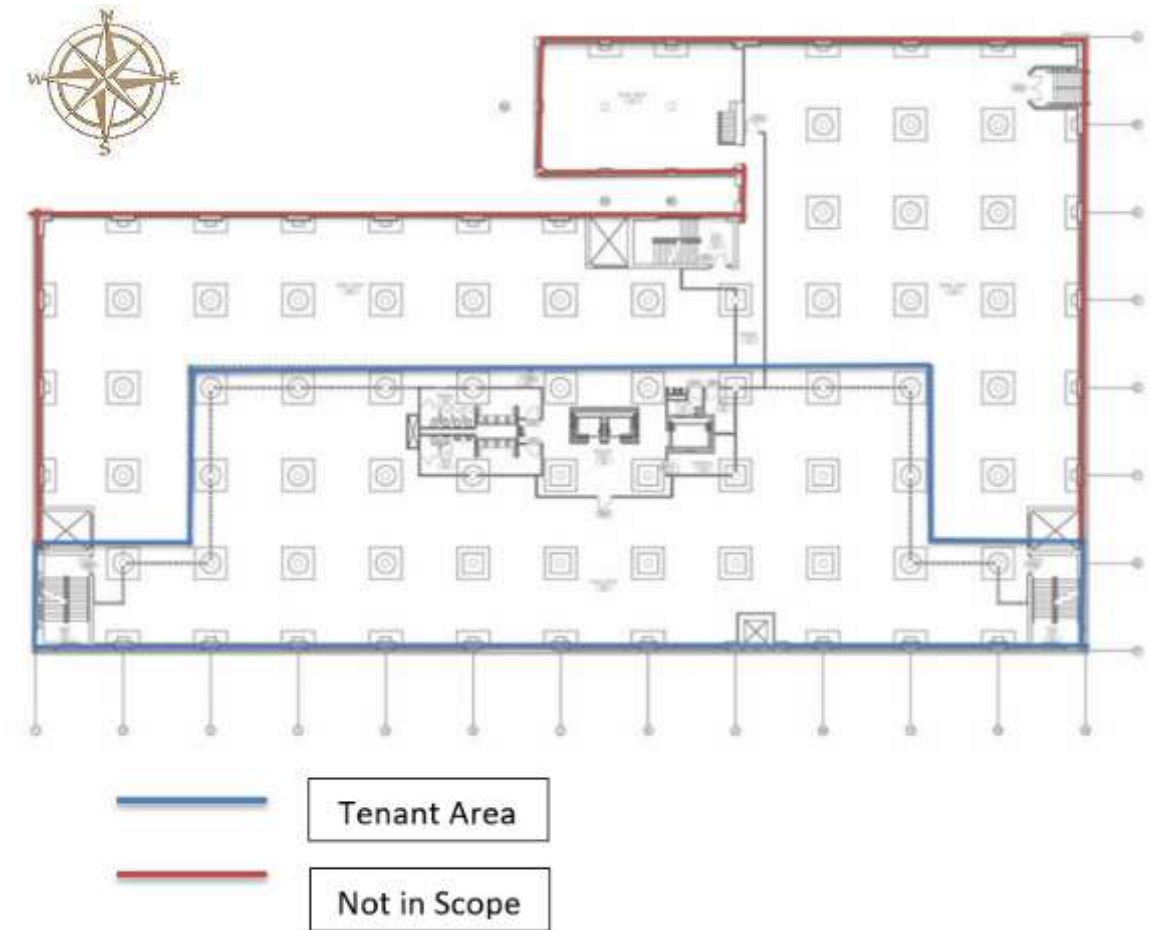

Site Analysis:

The Edgeworth Tobacco Building Richmond, VA

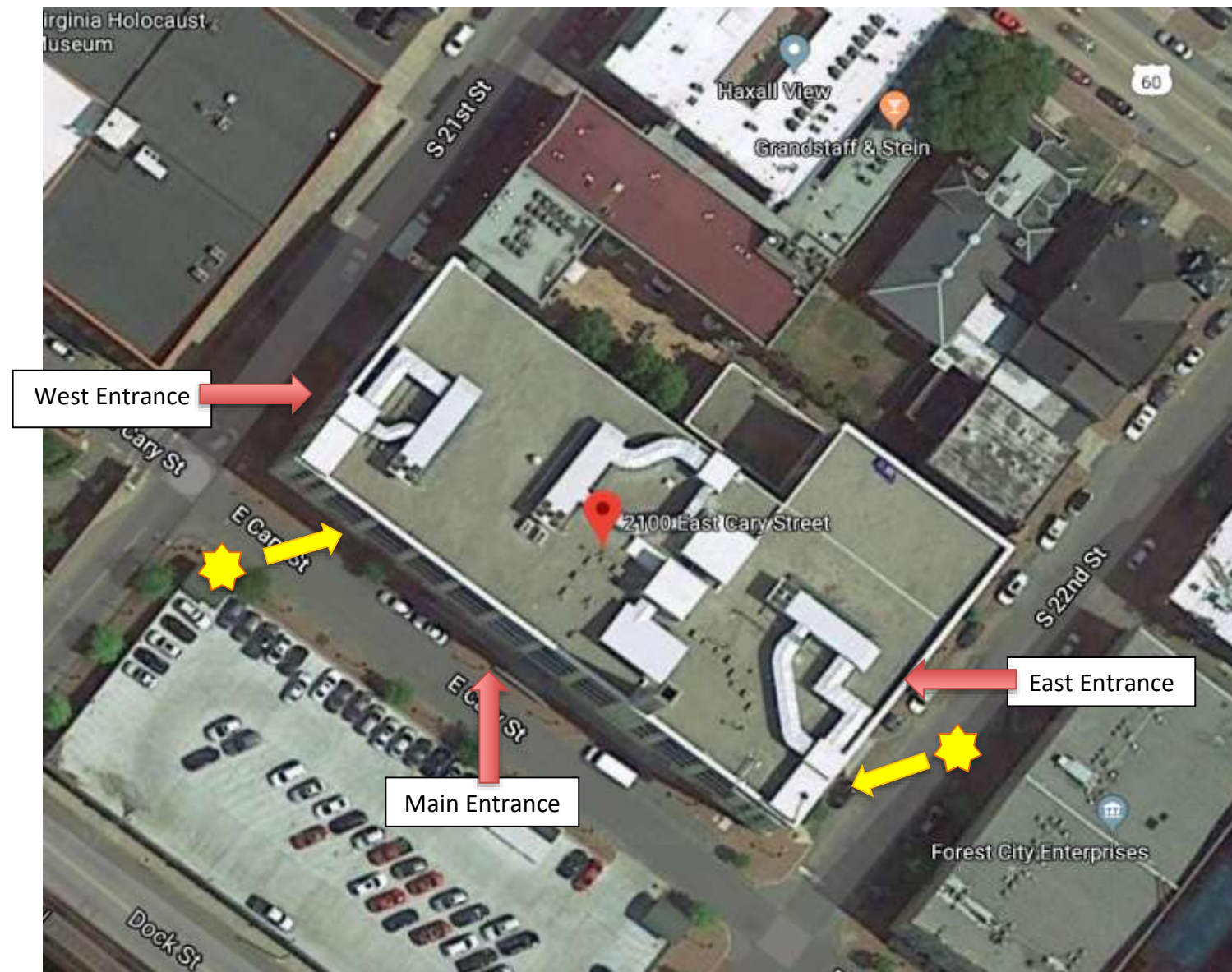

Neighborhood Views

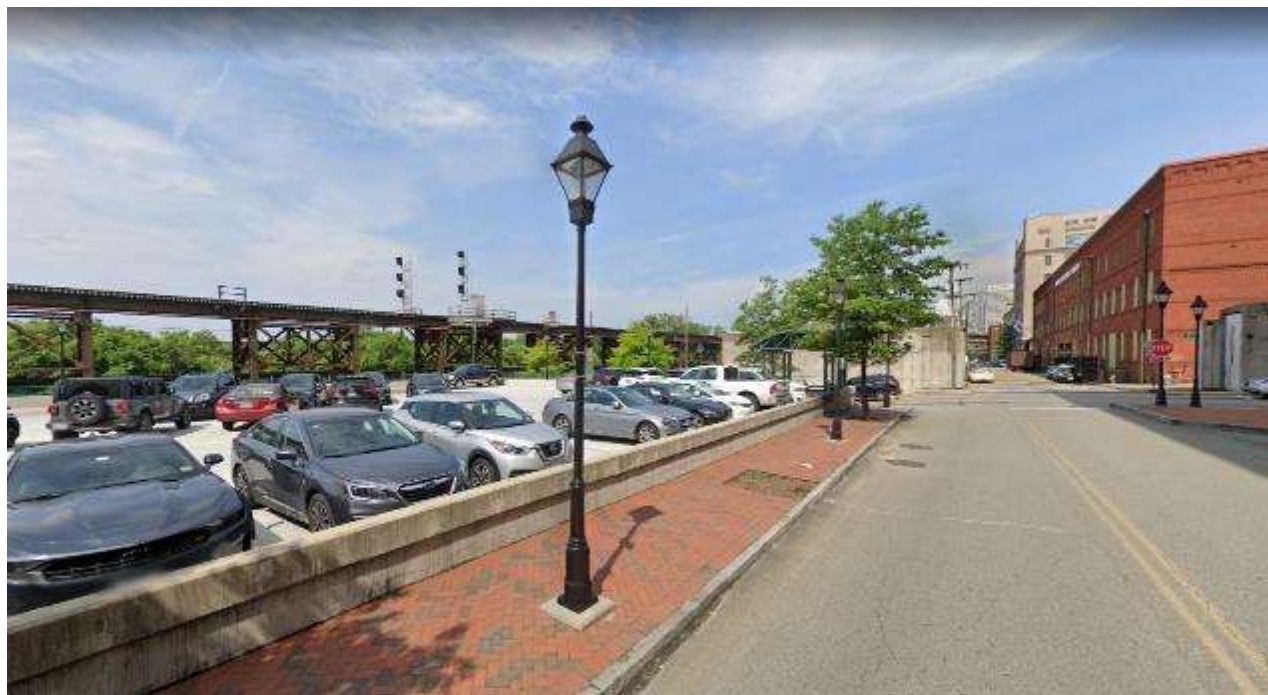

Space Program

IDSN 3202 - PROGRAM DOCUMENT

PERSONNEL AND WORK SPACES									
PERSONNEL									
Position	Personnel Totals		Unit Square Ft.		Extended Sq. Feet	Equipment			Notes
	Current	Future	Office	Workstation		PC	Printer	Fax	
Director		4	120		480		1		
Manager		8	120		960	2	1		
Assistant Manager		4		48	192				
Administrative Assistant		4		48	192	1	1		
Tech Assistant		55		48	2640	3	8		
Personnel Totals:		75			4464	6	11	0	
WORK SPACES									
Space	Support/Equipment		Unit Square Feet	Extended Sq. Feet	Location	Notes			
	Current	Future							
Open Work Area		1	500	500	Adjacent to Teams	Work counters			
Support Totals:				500					
SUPPORT/EQUIPMENT SPACES									
Space	Support/Equipment		Unit Square Feet	Extended Sq. Feet	Location	Notes			
	Current	Future							
Reception		1	500	500	Direct access to Entrance and Large Conference	Waiting for 6, TV's			
Large Conference Room		1	300	300	Next to Reception	Full AV			
Conference Room		2	120	240	Shared by all areas	Full AV			
Equipment Station		3	48	144	Spread throughout	Printers, shredder, work counter			
Pantry		1	120	120	Spread throughout	Coffee, sink, refrigerator, cabinets			
Employee Lounge		1	400	400		Full kitchen, seating			
Storage		1	120	120					
Mechanical Room		1	300	300	Near Base Building air supply	Supplemental Air			
Support Totals:				2124					

Department Summary Information:	
Personnel	4464 Square Ft.
Work	500 Square Ft.
Support	2124 Square Ft.
Sub Total:	7088 Square Ft.
Circulation	1.54
Total Rentable:	10916 Square Ft.

Interviewee:	
Interview Date:	
Revision Submitted:	
Sign Off:	

Department Notes:

Zenned Out: Concept and Inspiration

- Bringing the outdoors in
- Light, airy feel
- Calming
- Sense of Balance
- Cool Colors





Bubble Diagrams

Option 1

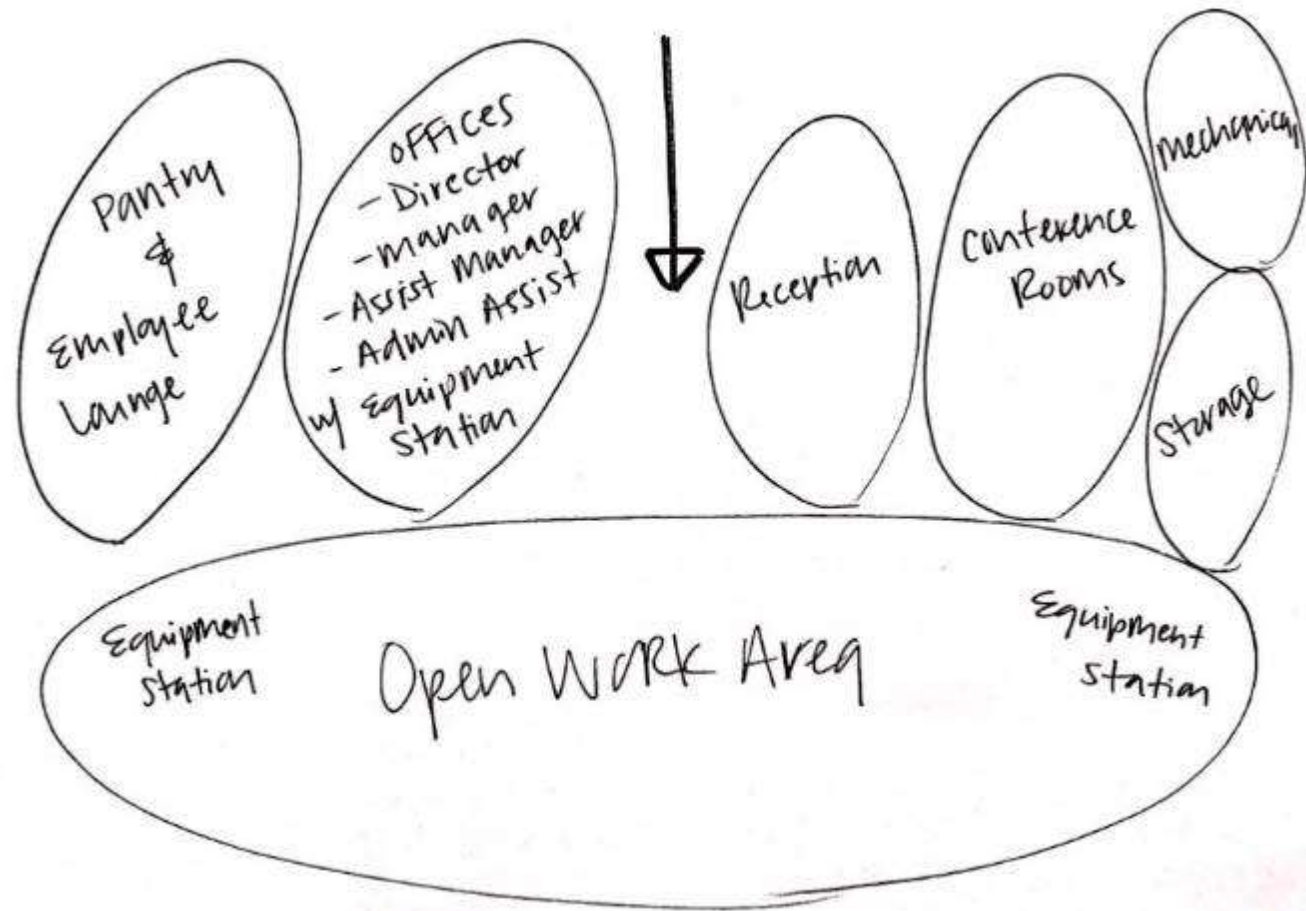

Option 2

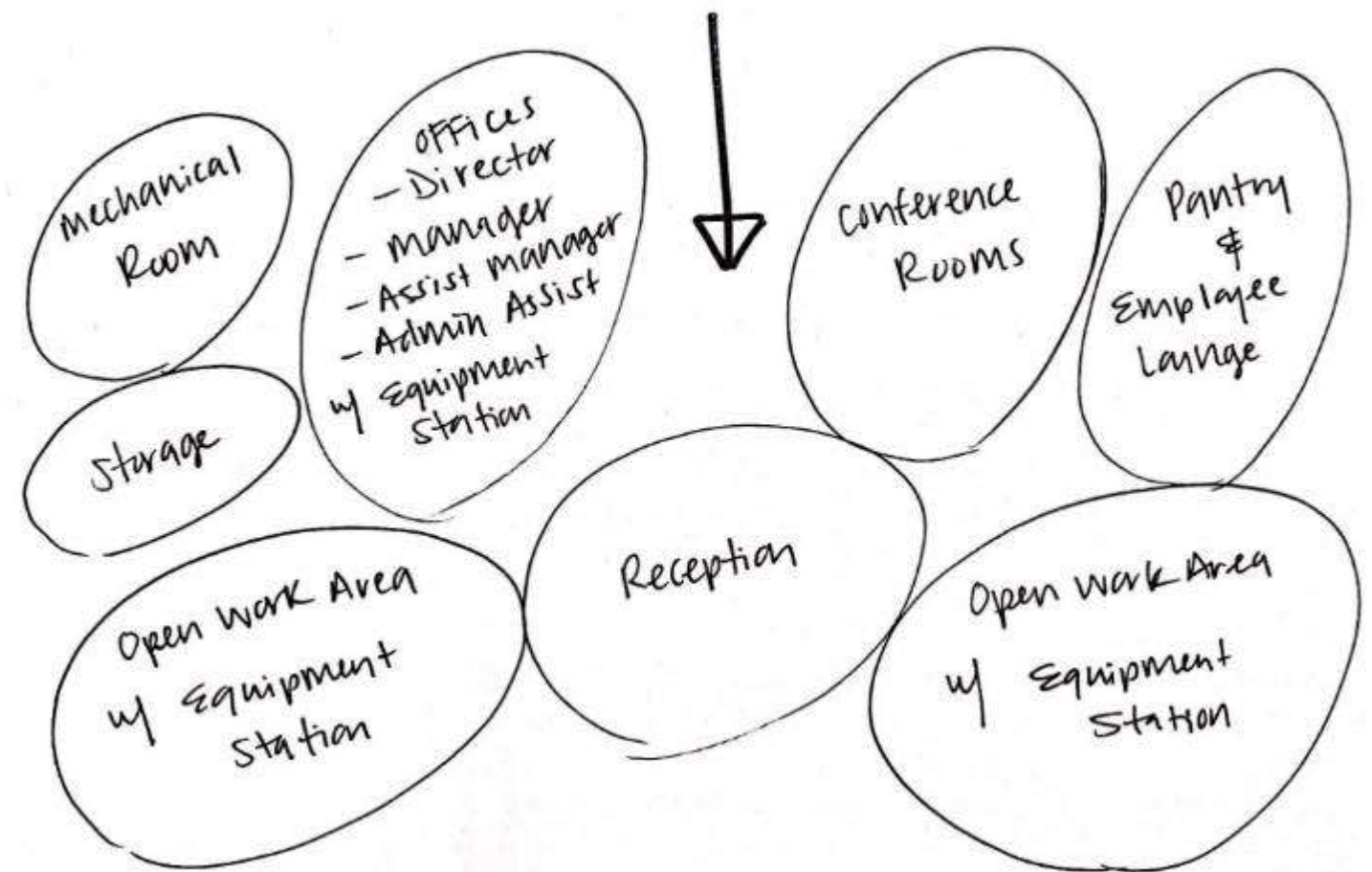

Blocking Diagrams

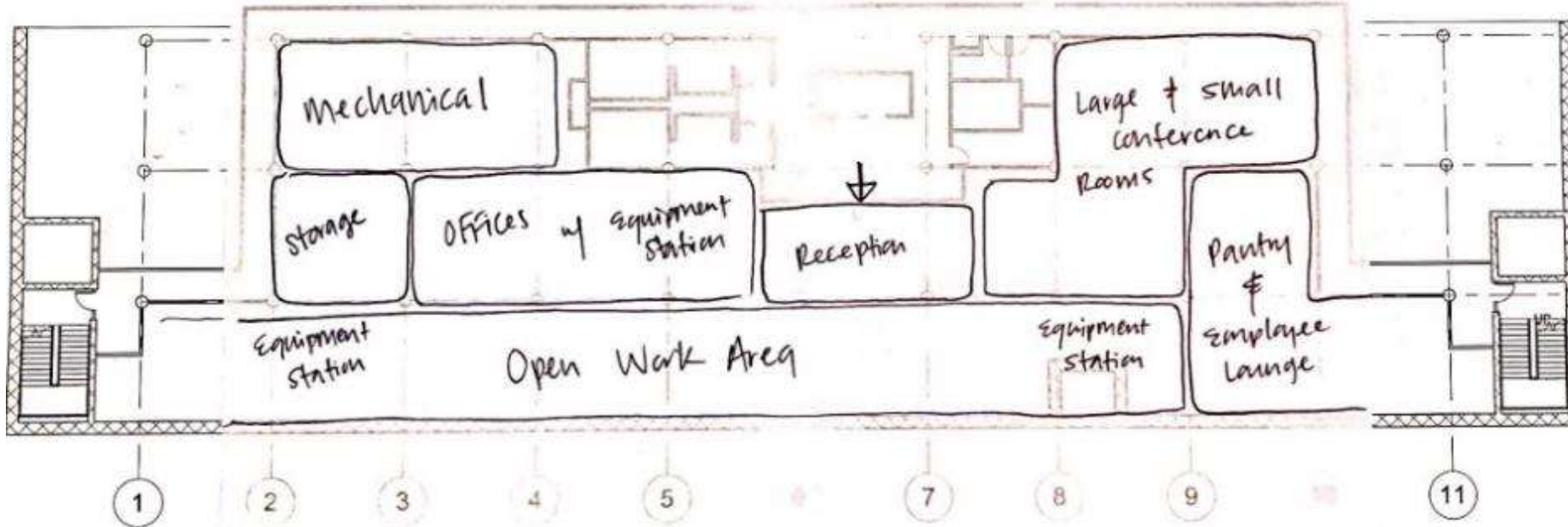

Option 1

Option 2

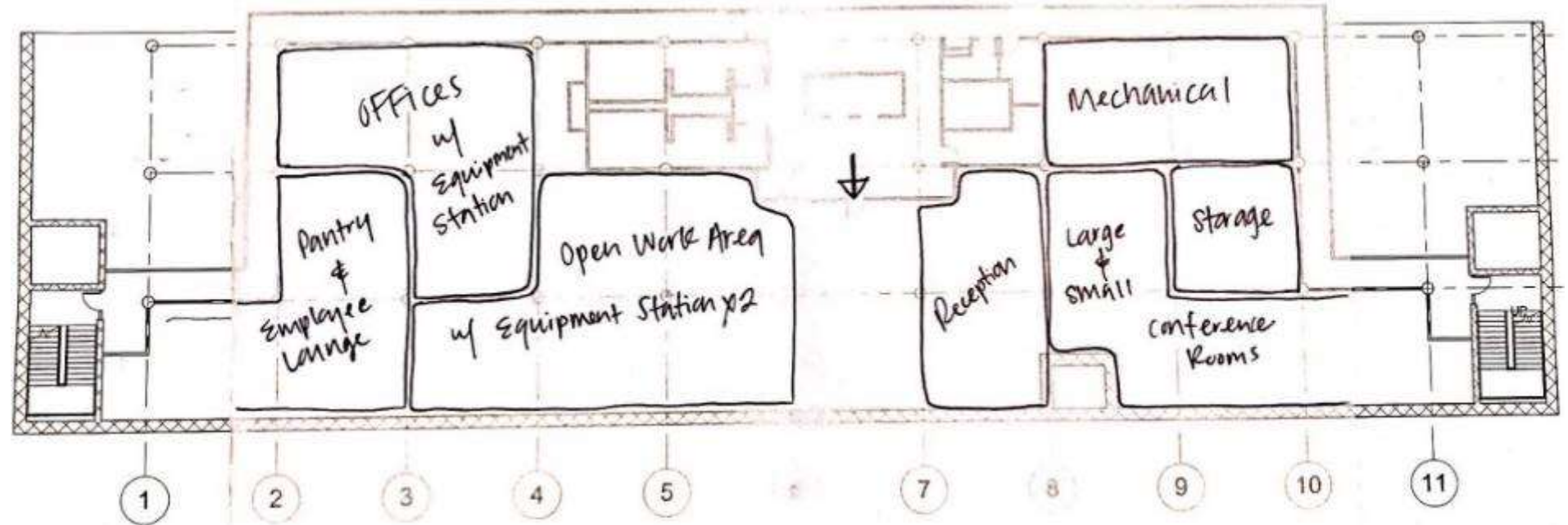

Space Standard: Offices

Option 1

Option 2

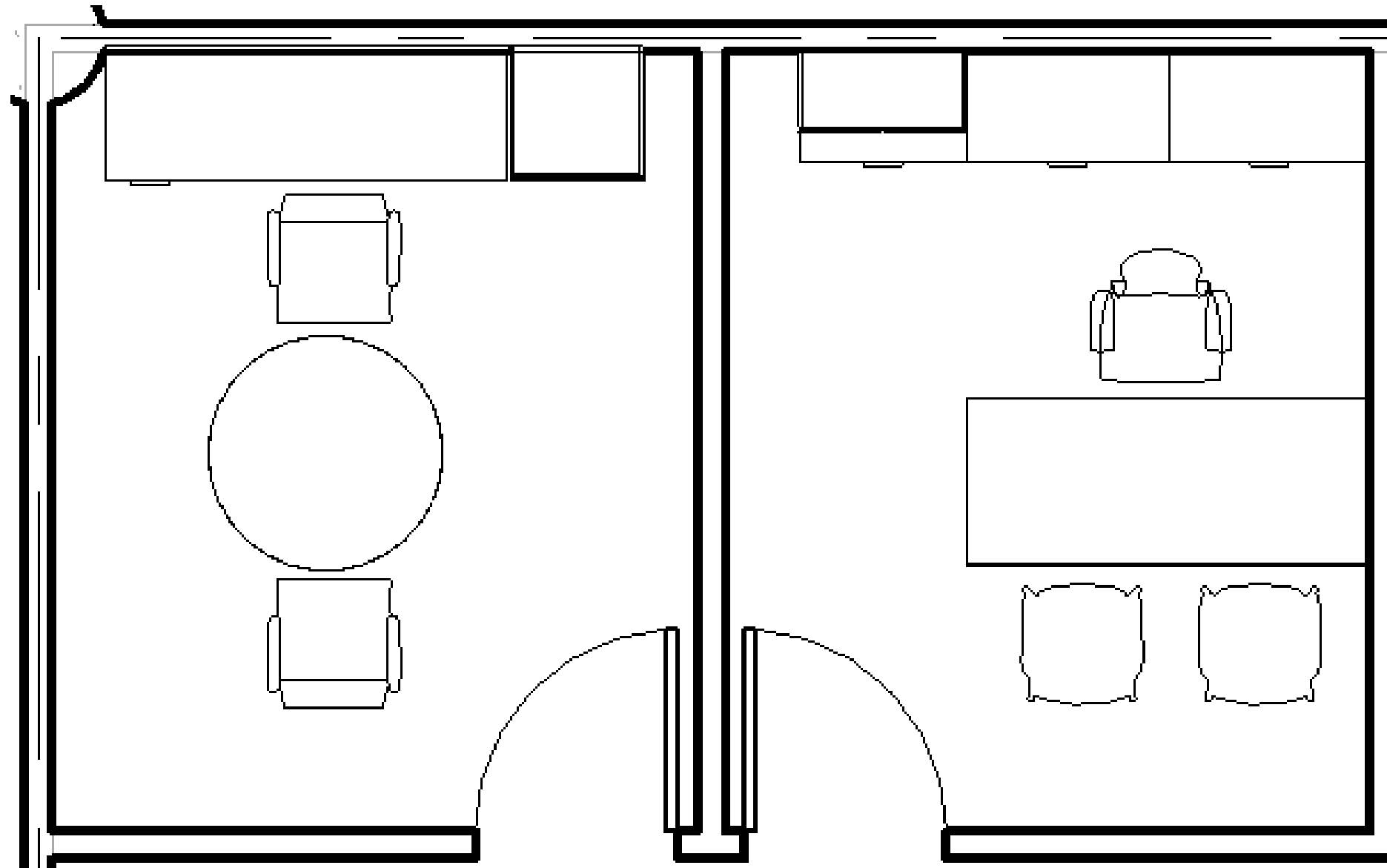

Space Standard: Workstations

Option 1

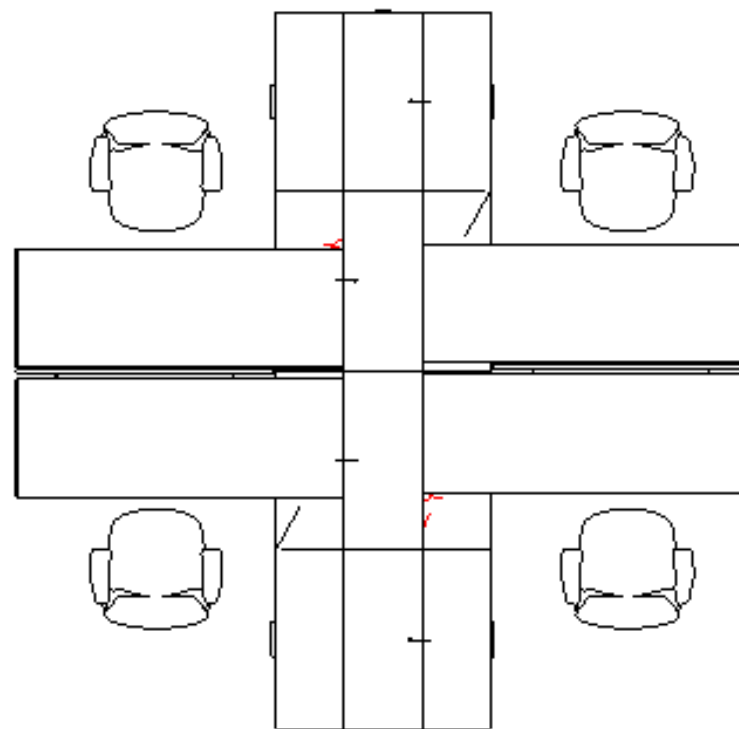

Option 2

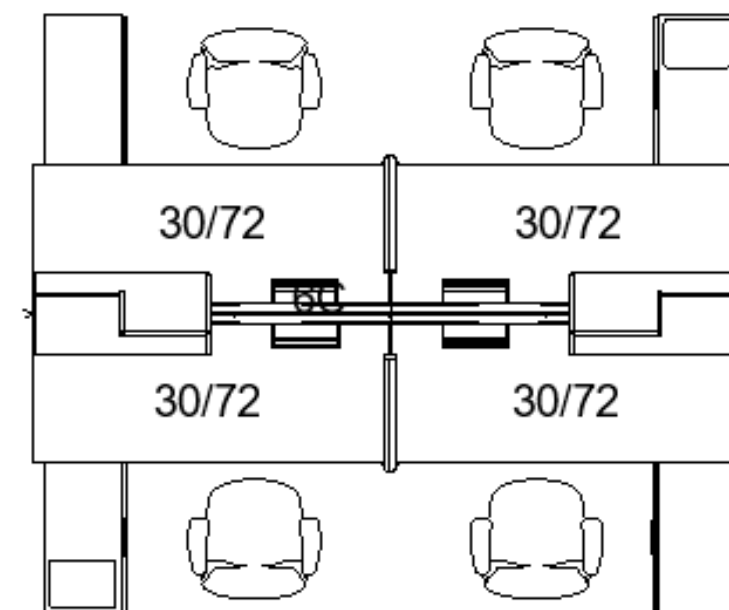

Activity Space Study: Intense Focus Work



Existing Space

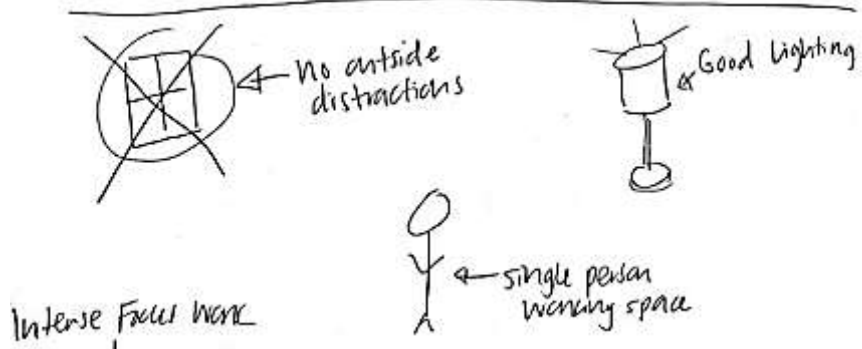
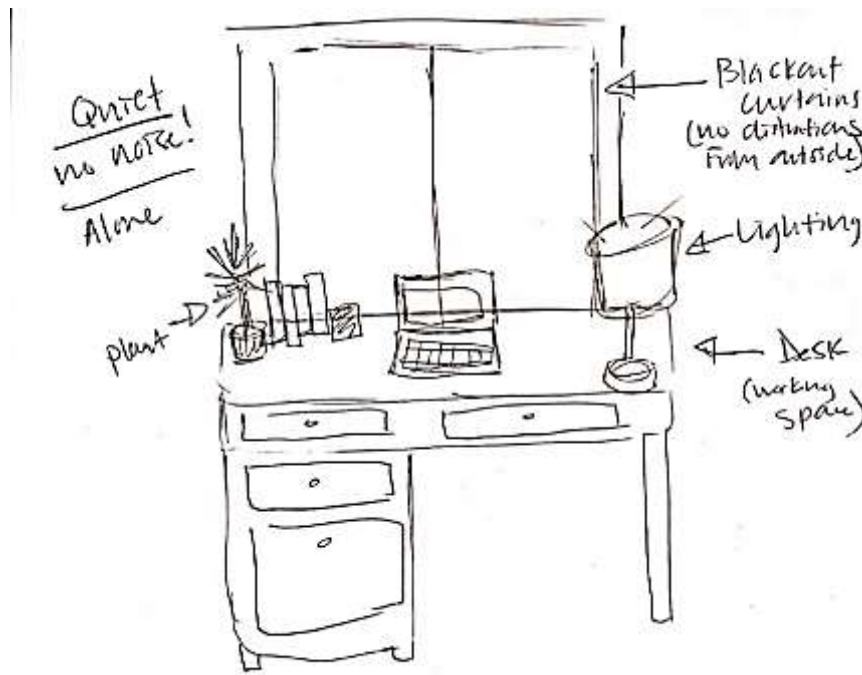

Ideal Space

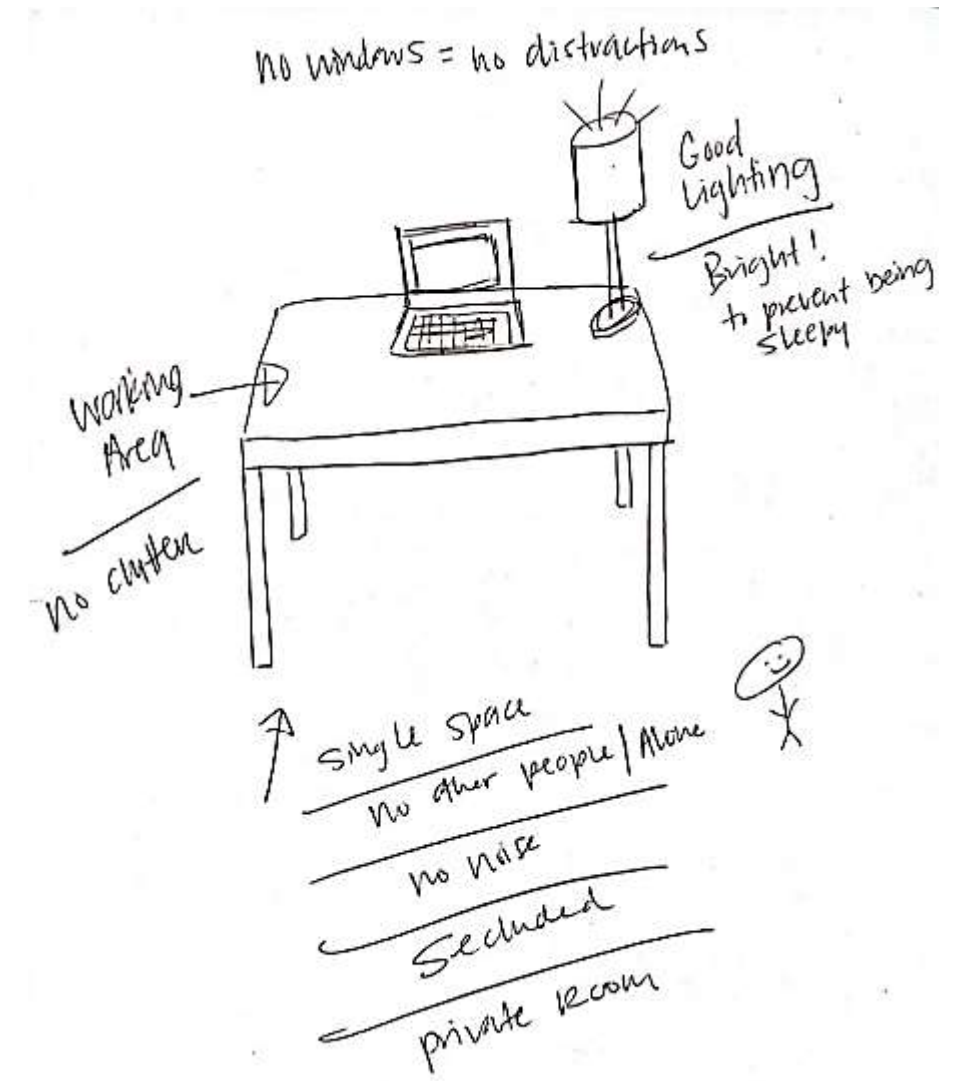

Activity Space Study: Daydreaming



Existing Space

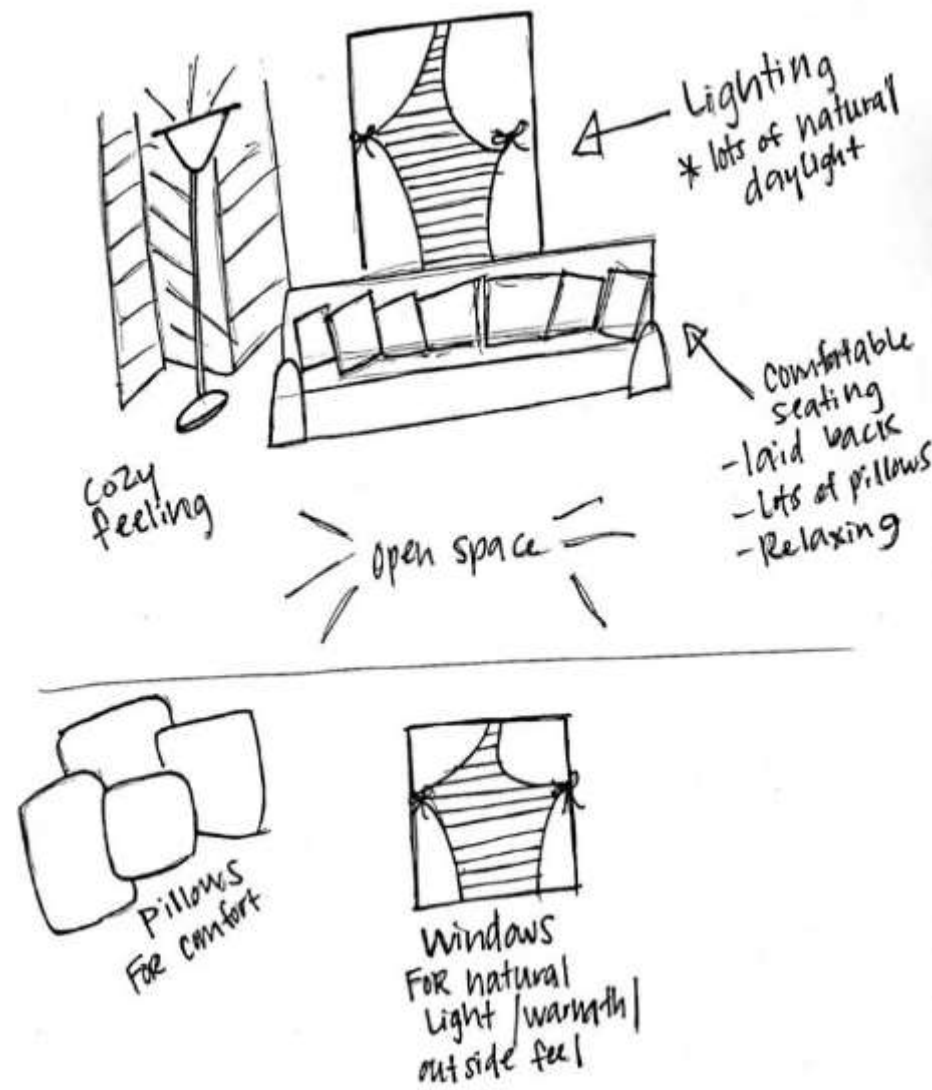

Ideal Space

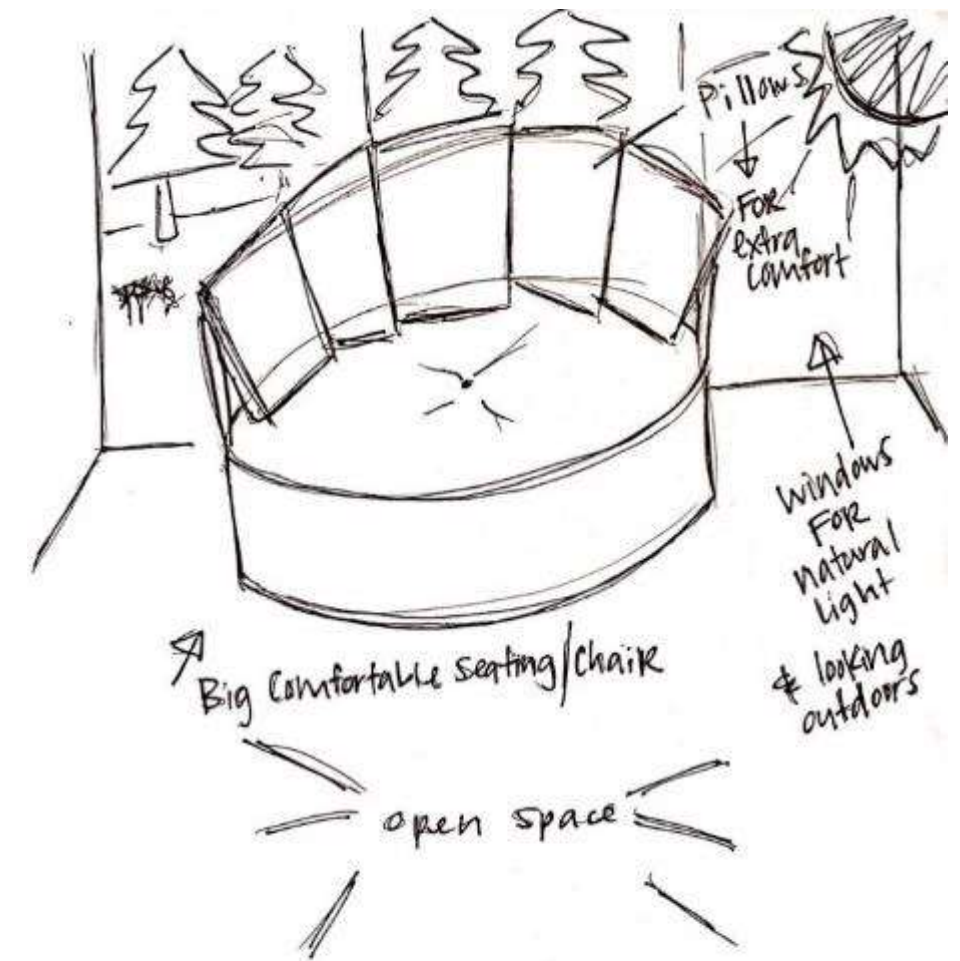

Activity Space Study: Socializing

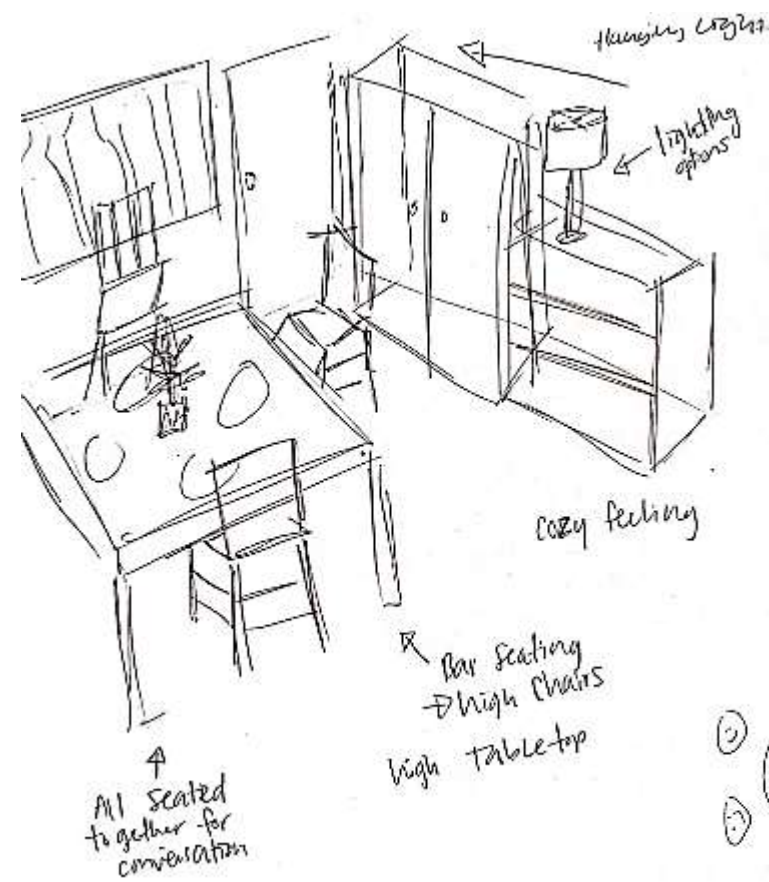

Existing Space

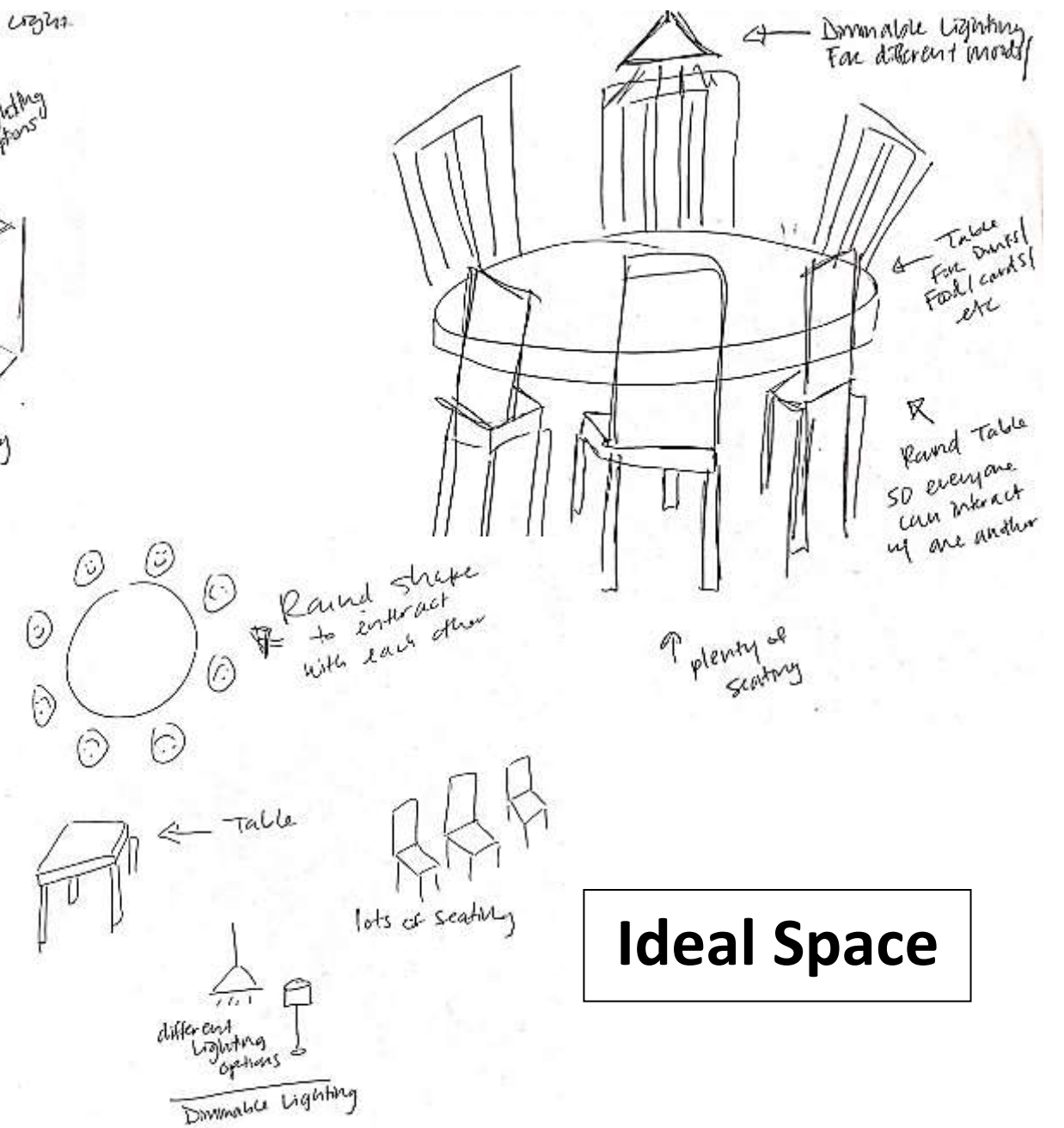

Ideal Space